

Measurement of the Laboratory's Absolute Velocity

STEFAN MARINOV¹

*Laboratory for Fundamental Physical Problems,
ul. Elin Pelin 22, Sofia 1421, Bulgaria*

Received June 28, 1979

Abstract

The report is given on a local measurement of the absolute velocity of a laboratory. This is the resultant velocity due to all types of motion in which the laboratory takes part (about the Earth's axis, about the Sun, about the galactic center, about the center of the cluster of galaxies).

Harress (1912) and Sagnac (1913) established that the velocity of light is direction dependent with respect to a rotating disk. Michelson, Gale, and Pearson (1925) showed that such direction dependence exists also for the spinning earth.

Until now the "Sagnac effect" has been measured only for closed paths of the light beams where the effect is proportional to the *angular* rotational velocity. We measured the "Sagnac effect" for light beams proceeding along a straight line where the effect is proportional to the *linear* rotational velocity. Michelson, Gale, and Pearson measured only the diurnal angular rotational velocity, since the yearly and galactic angular rotational velocities are too small to be detected. We registered the galactic and supergalactic linear rotational velocities and small changes in their sum due to the yearly rotation, when performing the measurement during the different days of the year; the diurnal changes, being very small, could not be registered.

To measure the Sagnac effect along a straight line, one has to realize a Newtonian time synchronization [1] between spatially separated points. We succeeded in making such a synchronization with the help of a rotating axle.

The scheme of our interferometric "coupled-mirrors" experiment, with

¹Present address: via Puggia 47, 16131 Genova, Italy.

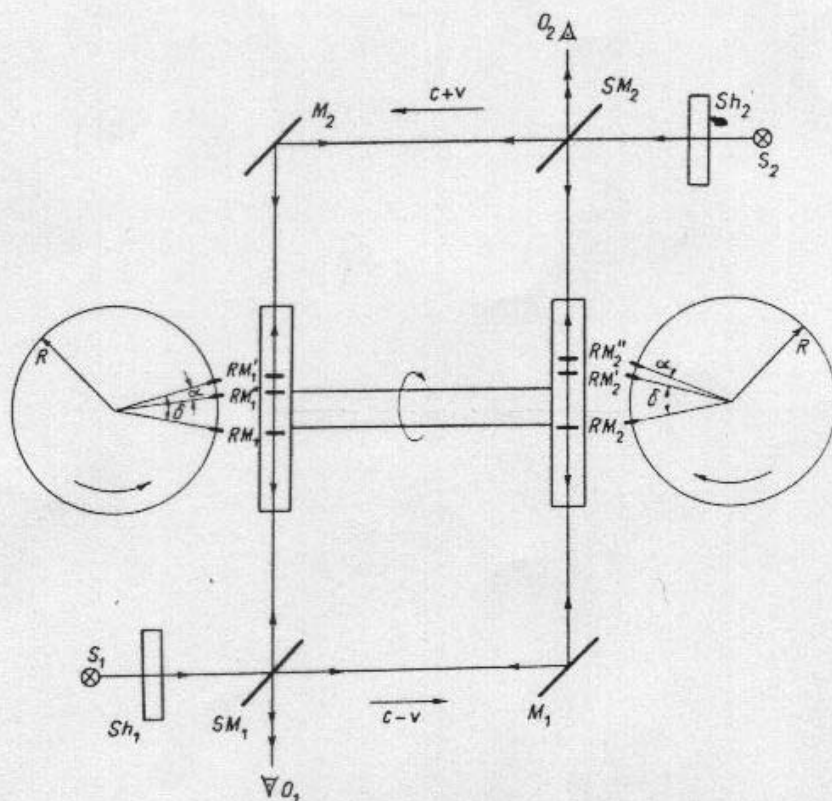

Fig. 1. The interferometric "coupled-mirrors" experiment.

whose help we measured the laboratory's absolute velocity, is the following (Figure 1).

Let us have a shaft with length d on whose ends there are two disks with radius R . On the rims of the disks, two mirrors RM_1 and RM_2 are fixed which we call the rotating mirrors. Monochromatic parallel light emitted by the source S_1 (or S_2) is partially reflected and partially refracted by the semitransparent mirror SM_1 (SM_2). The "transmitted" beam is then reflected successively by the mirror M_1 (M_2), by the rotating mirror RM_2 (RM_1), again by M_1 , SM_1 (M_2 , SM_2), and the observer O_1 (O_2) registers the interference which the "transmitted" beam makes with the "reflected" beam, the last one being reflected by the rotating mirror RM_1 (RM_2) and transmitted by SM_1 (SM_2). We call the direction from RM_1 to RM_2 "direct" and from RM_2 to RM_1 "opposite."

Let us now set the shaft in rotation with angular velocity Ω and let us put in action the shutters Sh_1 and Sh_2 which should allow light to pass through them only when the rotating mirrors RM_1 and RM_2 are perpendicular to the incident beams. This synchronization was performed by making the opening of the shutters ($\cong 10^{-6}$ sec) be governed by the rotating shaft itself. Later we realized that the shutters are not necessary and we used simple slits placed along the light paths to the rotating mirrors.

If, at rest, the "transmitted" light pulse reaches the second rotating mirror in

the position RM_2 (RM_1) when the first rotating mirror is in the position RM_1 (RM_2), then, in the case of rotating shaft, the "transmitted" pulse will reach the second rotating mirror in the position RM'_2 (RM'_1) when the velocity of light is equal to c , and in the position RM''_2 (RM''_1) when the velocity of light is equal to $c - v$ ($c + v$). Denoting by δ the angle between the radii of RM_2 and RM'_2 (RM_1 and RM'_1) and by α the angle between the radii of RM'_2 and RM''_2 (RM'_1 and RM''_1), we shall have

$$\delta \pm \alpha = \frac{d}{c \mp v} \Omega \quad (1)$$

from where (assuming $v \ll c$) we get $\alpha = \Omega dv/c^2$.

The difference in the difference of the optical paths of a "transmitted" and a "reflected" light pulse which interfere in the cases of presence and nonpresence of an "aether wind" with velocity v will be

$$\Delta = 2\alpha R = 2 \frac{dR\Omega}{c^2} v = 2d \frac{v_r v}{c^2} \quad (2)$$

where v_r is the linear velocity of the rotating mirrors.

If the wavelength of the light is λ and we maintain an angular velocity $\Omega = 2\pi N$ (N is the number of revolutions per second), then, during a rotation of the apparatus over 360° about an axis perpendicular to the absolute velocity v , the observers O_1 and O_2 should register changes in their interference pictures within

$$z = \frac{\Delta}{\lambda} = 4\pi \frac{dRN}{\lambda c^2} v \quad (3)$$

wavelengths.

In our actual setup, the "direct" beams are tangent to the *upper* parts of the rotating disks, while the "opposite" light beams are tangent to their *lower* parts. Thus the reflection of the "direct" and "opposite" beams proceeds on the same planes of the mirrors. The "observers" in our actual setup represent two photoresistors which are put in the "arms" of a Wheatstone bridge. The changes in both interference pictures are *exactly opposite*. Thus in our apparatus the mirrors RM_1 and RM_2 are exactly parallel and the photoresistors are illuminated *not* by a pattern of interference fringes but *uniformly*.

A very important difference between the deviative "coupled-mirrors" experiment [2] and the present one, which we call interferometric, is that the effect registered in the latter is independent of small variations in the rotational velocity. In the interferometric variant one *need not* keep the illumination over one of the photoresistors constant by changing the velocity of rotation when rotating the axis of the apparatus, but need merely register the *difference* in the illuminations over the photoresistors during the rotation. This (together with the high resolution of the interferometric method) is the most important advantage of the interferometric "coupled-mirrors" experiment.

Since the illumination over the photoresistors changes with the change in the difference in the optical paths of the "reflected" and "transmitted" beams according to the sine law, the apparatus has the highest sensitivity when the illumination over the photoresistors is the average one (for maximum and minimum illumination the sensitivity falls to zero). Hence a change in the velocity of rotation leads to a change in the sensitivity. Let us consider this problem.

If the resistance of the photoresistors changes *linearly* with the change in the illumination (as was the case in our setup), then to a small change dI in the energy flux density a change

$$dW = kdI = -k \frac{I_{\max}}{2} \sin \varphi d\varphi \quad (4)$$

in the resistance of the photoresistors will correspond, k being a constant, I_{\max} the maximum possible energy (light) flux density, and φ the difference between the phases of the intensities in the "reflected" and "transmitted" beams.

For a change $\Delta\varphi = \pi$ the resistance will change with $W = -kI_{\max}$, as follows after the integration of equation (4).

Since it is $\Delta\varphi = 2\pi\Delta/\lambda$, then for $\varphi = \pi/2$, where the sensitivity is the highest, we shall have $\Delta W/W = \pi\Delta/\lambda$. Substituting this into equation (3), we obtain

$$v = \frac{\lambda c^2}{4\pi^2 dRN} \cdot \frac{\Delta W}{W} \quad (5)$$

The measuring method is: We set such a rotational rate N_1 that the illumination over the photoresistors will be minimum. Let us denote the resistance of the photoresistors under such a condition by W_1 and W_2 (it must be $W_1 = W_2$). We put the same constant resistances in the other two arms of the bridge, so that the same current J_0 (called the initial current) will flow through the arms of the photoresistors, as well as through the arms of the constant resistors, and no current will flow through the galvanometer in the bridge's diagonal. Then we set such a rotational rate N_2 that the illumination over the photoresistors is maximum and we connect in series with them two variable resistors, W , so that again the initial current J_0 has to flow through all arms of the bridge. After that we make the illumination average, setting a rotational rate $N = (N_1 + N_2)/2$ and we diminish correspondingly the variable resistors, so that again the initial current has to flow through all arms of the bridge and no current in the diagonal galvanometer. Now if we rotate the axis of the apparatus from a position perpendicular to its absolute velocity to a position parallel to its absolute velocity and we transfer resistance ΔW from the arm where the illumination over the photoresistor has decreased to the arm where it has increased, again the same initial current will flow through all arms and no current through the diagonal galvanometer. The absolute velocity is then to be calculated from equation (5).

When the illuminations over the photoresistors were averaged a change $\delta W =$

8×10^{-4} W in any of the arms of the photoresistors (positive in the one and negative in the other) could be discerned from the fluctuations of the bridge's galvanometer, and thus the resolution was

$$\delta v = \frac{\lambda c^2}{4\pi^2 dRN} \cdot \frac{\delta W}{W} = 17 \text{ km/sec} \quad (6)$$

The errors that can be introduced from the imprecise values of $d = 140$ cm, $R = 40.0$ cm, $N = 120$ rev/sec, and $\lambda = 633$ nm (a He-Ne laser) are substantially smaller than the resolution and can be ignored. To guarantee sufficient certainty, we take $\delta v = 20$ km/sec.

The experiment was not performed in vacuum.

The room was not temperature controlled, but it is easy to calculate that reasonable thermal and density disturbances of the air along the different paths of the interfering light beams cannot introduce errors larger than the accepted one.

The whole apparatus is mounted on a platform which can rotate in the horizontal plane and the measurement can be performed in a couple of seconds.

The magnitude and the apex of the Earth's (laboratory's) absolute velocity have been established as follows:

During a whole day we search for the moment when the Wheatstone bridge is in equilibrium if the axis of the apparatus points east-west. At this moment the Earth's absolute velocity lies in the plane of the laboratory's meridian. Thus, turning the axis of the apparatus north-south, we can measure v in the horizontal plane of the laboratory. The same measurement is to be made after 12 hr. As can be seen from Figure 2, the components of the Earth's absolute velocity in the horizontal plane of the laboratory for these two moments are

$$v_a = v \sin(\delta - \varphi), \quad v_b = v \sin(\delta + \varphi) \quad (7)$$

where φ is the latitude of the laboratory and δ is the declination of the apex. From these we obtain

$$v = \frac{[v_a^2 + v_b^2 - 2v_a v_b (\cos^2 \varphi - \sin^2 \varphi)]^{1/2}}{2 \sin \varphi \cos \varphi} \quad (8)$$

$$\tan \delta = \frac{v_b + v_a}{v_b - v_a} \tan \varphi$$

We take v_a and v_b as positive when they point to the north and as negative when they point to the south. Obviously, the apex of the absolute velocity points to the meridian of this component whose *algebraic* value is smaller. Thus we shall always assume $v_a < v_b$ and then the right ascension α of the apex will be equal to the local sidereal time of registration of v_a . We could establish this moment within a precision of ± 15 min. Thus we can calculate (with an accuracy not larger

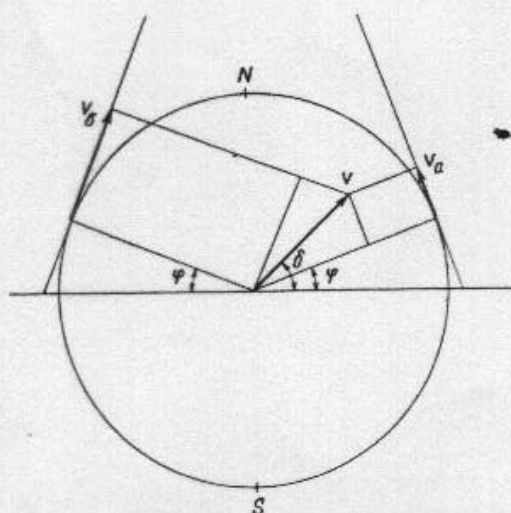

Fig. 2. The components of the laboratory's absolute velocity in the plane of the meridian.

than ± 5 min) the sidereal time t_{si} for the meridian where the local time is the same as the standard time t_{st} of registration, taking into account that sidereal time at a middle midnight is as follows:

22 September:	0 ^h	23 March:	12 ^h
22 October:	2 ^h	23 April:	14 ^h
22 November:	4 ^h	23 May:	16 ^h
22 December:	6 ^h	22 June:	18 ^h
21 January:	8 ^h	23 July:	20 ^h
21 February:	10 ^h	22 August:	22 ^h

Our first measurement of the Earth's absolute velocity with the help of the interferometric "coupled-mirrors" experiment was performed on 12 July 1975 in Sofia ($\varphi = 42^\circ 41'$, $\lambda = 23^\circ 21'$). We registered

$$\begin{aligned} v_a &= -260 \pm 20 \text{ km/sec}, & (t_{st})_a &= 18^h 37^m \pm 15^m \\ v_b &= +80 \pm 20 \text{ km/sec}, & (t_{st})_b &= 6^h 31^m \pm 15^m \end{aligned} \quad (9)$$

Thus

$$\begin{aligned} v &= 279 \pm 20 \text{ km/sec} \\ \delta &= -26^\circ \pm 4^\circ, & \alpha &= (t_{si})_a = 14^h 23^m \pm 20^m \end{aligned} \quad (10)$$

We repeated the measurement exactly six months later on 11 January 1976 when the Earth's rotational velocity about the Sun is oppositely directed. We registered

$$\begin{aligned} v_a &= -293 \pm 20 \text{ km/sec}, & (t_{st})_a &= 6^h 24^m \pm 15^m \\ v_b &= +121 \pm 20 \text{ km/sec}, & (t_{st})_b &= 18^h 23^m \pm 15^m \end{aligned} \quad (11)$$

Thus

$$\begin{aligned} v &= 327 \pm 20 \text{ km/sec} \\ \delta &= -21^\circ \pm 4^\circ, \quad \alpha = (t_{si})_a = 14^h 11^m \pm 20^m \end{aligned} \quad (12)$$

For v and δ we have taken the root-mean-square error, supposing for simplicity $\varphi \cong 45^\circ$. The right ascension is calculated from the moment when v_a is registered, i.e., from $(t_{st})_a$, since for this case ($|v_a| > |v_b|$) the sensitivity is better. If our measurements are accurate enough, then t_{st} , which is taken as the second, must differ with $11^h 58^m$ from t_{st} , which is taken as the first, because of the difference between solar and sidereal days.

The magnitude and the equatorial coordinates of the apex of the Sun's absolute velocity will be given by the arithmetical means of the figures obtained for the Earth's absolute velocity in July and January:

$$\begin{aligned} v &= 303 \pm 20 \text{ km/sec} \\ \delta &= -23^\circ \pm 4^\circ, \quad \alpha = 14^h 17^m \pm 20^m \end{aligned} \quad (13)$$

Wilkinson and Corey [3], analyzing the slight anisotropy in the cosmic background radiation, obtained the following figures for the Earth's absolute velocity (the epoch is not given):

$$\begin{aligned} v &= 320 \pm 80 \text{ km/sec} \\ \delta &= -21^\circ \pm 21^\circ, \quad \alpha = 12^h \pm 1^h \end{aligned} \quad (14)$$

It is beyond doubt that the absolute velocity of the laboratory measured by our method locally and when observing the slight anisotropy of the cosmic background radiation is the same physical quantity.

In Figure 3 we show the different rotational velocities in which our Earth takes part: v_E is the Earth's velocity about the Sun, which changes its direction with a period of one year; v_S is the Sun's velocity about the galactic center, which changes its direction with a period of 200 millions years; v is the geometrical sum of these two and of the velocity of our Galaxy about the center of the galactic cluster, which we measure with our apparatus. If we subtract geometrically v_S ($v_S = 250 \text{ km/sec}$, $\delta = 27^\circ 51'$, $\alpha = 19^h 28^m$) from v [see the figures in equation (13)], we shall obtain the rotational velocity of our galaxy.

Let us now compare the figures in equation (10) with these obtained in 1973 with the help of the deviative "coupled-mirrors" experiment [2]. In 1973 the axis of the apparatus was fixed in the horizontal plane with an azimuth $A' = 84^\circ$. For the sake of simplicity (see Figure 3), we shall assume $A = 90^\circ$. In a day the axis of the deviative "coupled-mirrors" implement rotated in a plane parallel to the equatorial and thus the velocity $v'_{eq} = 130 \pm 100 \text{ km/sec}$, which we measured, was the projection of the absolute velocity v in the equatorial plane. Proceeding from Figure 3, we obtain $v_{eq} = 251 \text{ km/sec}$, if we use the

center. This theorem thus affirms that the motion of *any* material object in our world is non-inertial. Is, however, saved in this way the principle of relativity? No, it isn't. My "coupled-mirrors" experiments impel the scientific community to definitely reject the principle of relativity as not adequate to physical reality and restore the aether model of light propagation.

After the discovery of a "new aether wind" when analysing the slight anisotropy in the cosmic background radiation, the leading scientists tried to save the principle of relativity, arguing that one has registered the "relative" velocity of the Earth with respect to a certain "material object" which is presented by the isotropically propagating background radiation. Well, my "coupled-mirrors" experiments represent registration of this "aether wind" in a closed laboratory! It is clear that to recognize the failure of the principle of relativity in the third fourth of the Twentieth century is a very hard nut for the scientific community. But this nut must be cracked. The sooner the better.

I must note that many scientists are doubtful whether I, indeed, have registered the effects reported in this paper and of the different high-velocity light experiments reported in the monograph [4]. So, for example, Prof. P. Bergmann wrote me a year ago: "I affirm that your "coupled-mirrors" experiment must give a null result, and the effects registered by you are due to side causes." In my answer I wrote: "If you shall publish this opinion in the press, I shall immediately send you \$500." I heard no more from Bergmann.

I should like to mention that my friend Prof. Prokhovnik, a member of the organizing committee of the International Conference on Space-Time Absoluteness which had to meet in May, 1977 in Bulgaria but was prohibited by the Bulgarian government, dedicated an *excellent* critical paper to the "coupled-mirrors" experiment [5]. Prof. Prokhovnik, as Lorentz, Builder, Ives, and Janossy, defends the conception of the world aether; however, according to him, a certain "twist" will appear in the rotating axle which will annihilate the positive "aether wind" effect. I called this the "Lorentz twist" [6]. My experiments undoubtedly show that such a *hypothetical* "Lorentz twist" does not exist. According to my absolute space-time theory [1], the "Lorentz contraction" does not represent a physical effect. The null result in the Michelson-Morley experiment and the specific (*not entirely Newtonian*) character of the Lienard-Wiechert potentials [1] impel us to introduce certain changes in the traditional *aether-Newtonian* character of light propagation. I called this slightly revised model (only within effects of second order in v/c) the *aether-Marinov* model of light propagation [7].

Finally, I wish to inform the reader that in 1979, I carried out the differential "coupled-shutters" experiment in the Free University of Brussels, with whose help for the first time in history the unidirectional light velocity has been measured in a laboratory [8]. It is highly astonishing that the differential "coupled-shutters" experiment represents, maybe, *the most simple and easily realisable* experiment for a laboratory measurement of the light velocity, and can

be set up in a couple of days in any college. It must be noted that the differential "coupled-shutters" experiment offers better technical possibilities for registration of the laboratory's absolute velocity than the interferometric "coupled-mirrors" experiment, and its theoretical explanation is much more simple.

References

1. Marinov, S. (1975). *Int. J. Theor. Phys.*, **13**, 189.
2. Marinov, S. (1974). *Czech. J. Phys.*, **B24**, 965.
3. Wilkinson, and Corey (1978). *Physics Today*, **January**, 17.
4. Marinov, S. (1977). *Eppur si muove* (C.B.D.S., Bruxelles).
5. Prokhovnik, S. J. (1979). *Found. Phys.*, **9**, 883.
6. Marinov, S. (1978). *Spec. Science and Techn.*, **1**, 520.
7. Marinov, S. (1979). *Found. Phys.*, **9**, 445.
8. Marinov, S. (1980). *Spec. Science and Techn.*, **3**, issue no. 1.